

# AMINO ACID ANALYZER SYSTEM S 633

- ◆ PROTEIN HYDROLYSATES
- ◆ PHYSIOLOGICAL FLUIDS
- ◆ BIOGENIC AMINES



# AMINO ACID ANALYZER S 633

The *Amino Acid Analyzer S 633* is the latest generation of Amino Acid Analyzer produced by Sykam for more than 30 years.

The modular proven design of the new Model

*S 633* features the latest technological advancements in the field of analytical instruments.

The whole system is inert and suitable for biological samples.

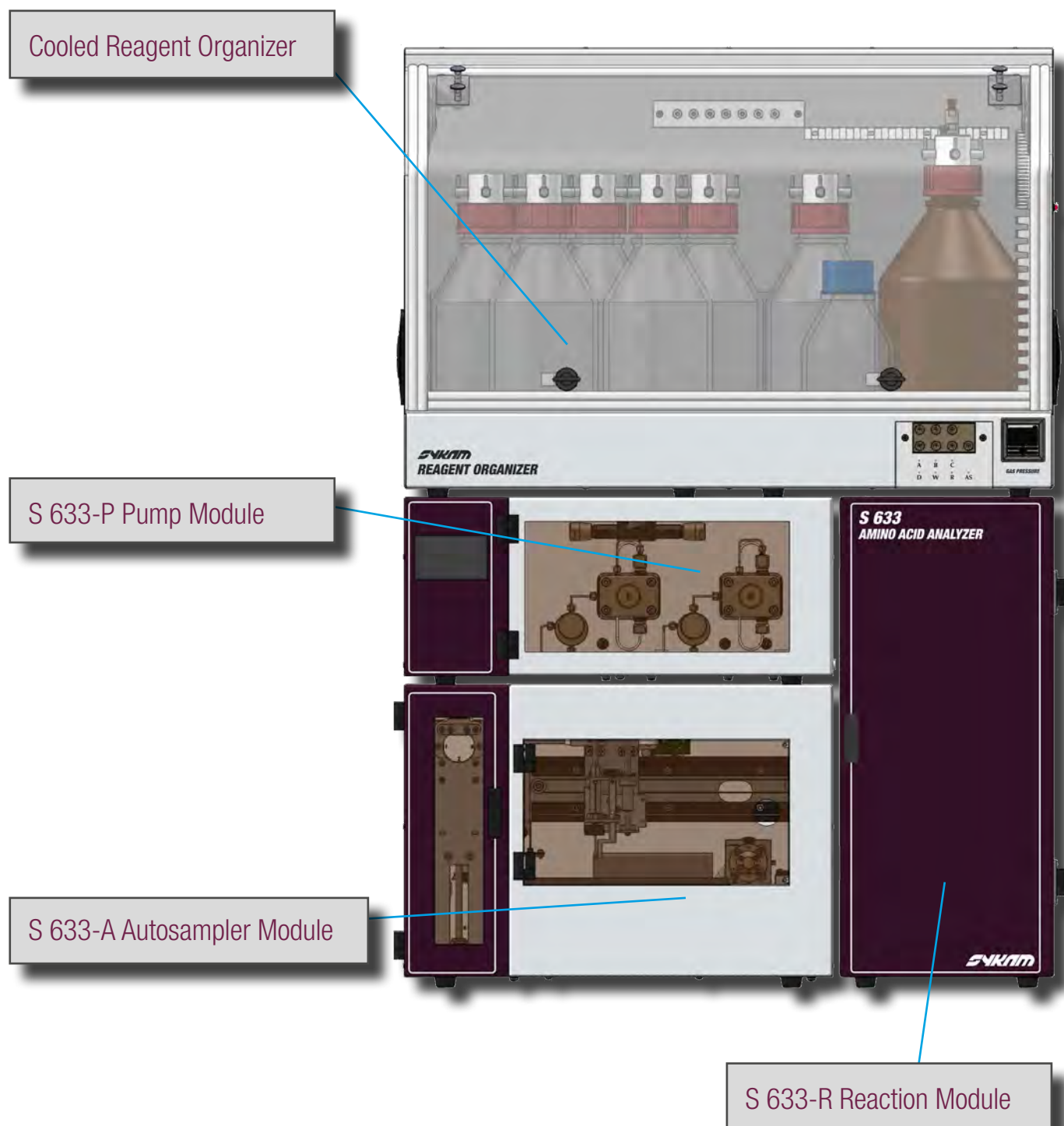

## Amino Acid Applications

The Amino Acid Analyzer offers a high range of analysis profile from a variety of applications.

- Sample Matrices
  - Protein Hydrolysates
  - Physiological Fluids (Serum/Urine)
  - Pharmaceutical Sample
- Applications / Features
  - Inborn Metabolism Errors
  - Feedstuff
  - Foodstuff
  - Biogenic Amines
  - Pharma Quality Control
  - Pharma Conformity (*Pharmacopoea*)

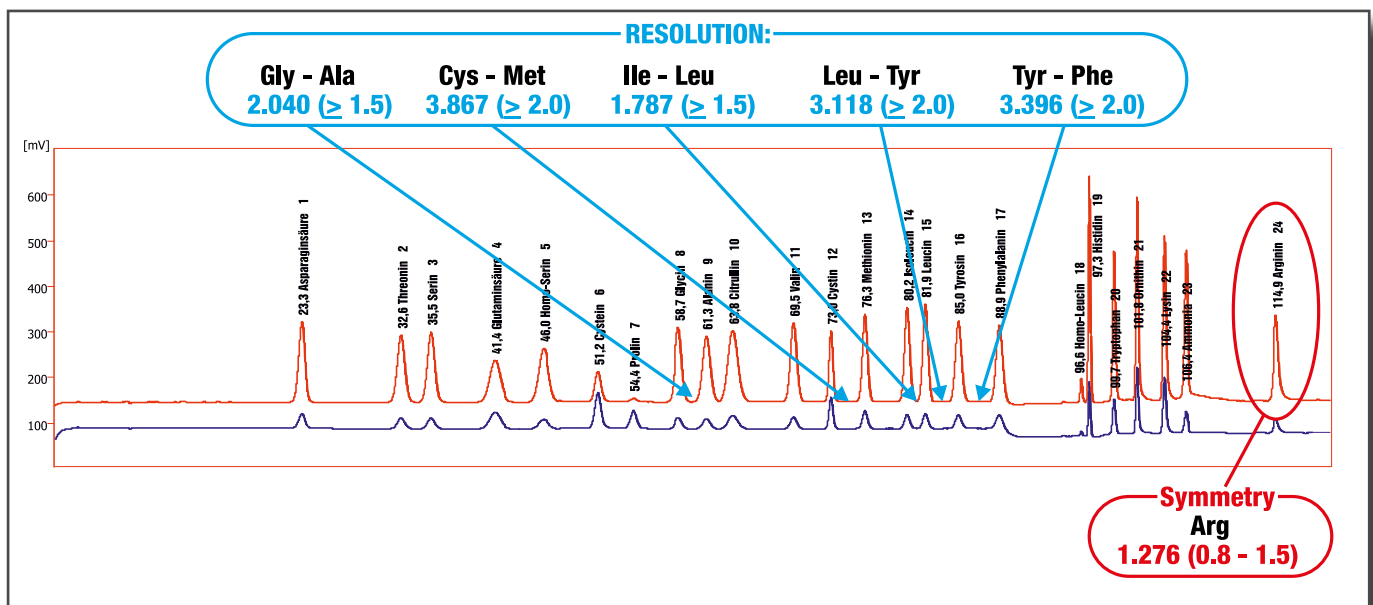

Pharmacopoea Requirements for Amino Acid Analysis

# PUMP MODULE S 633-P

The **Pump Module S 633-P** is a solvent delivery system consisting of three major parts:

## Low Pressure Gradient Pump

The low low pressure gradient pump is a reliable HPLC-grade pump system with an active gradient mixer. The mixer volume is adjustable between 100 and 900  $\mu$ l.

## Reagent Pump

The isocratic reagent pump delivers the post-column derivatization agent. A reliable solenoid valve is used for

the selection of reagent and washing solution.

## Online Degasser

The integrated vacuum degasser uses 7 separate channels to degass all available solvents and reagents important for the analysis: the four gradient buffers, the reagent and washing solution of the reagent pump and an additional channel for the autosampler washing solution.

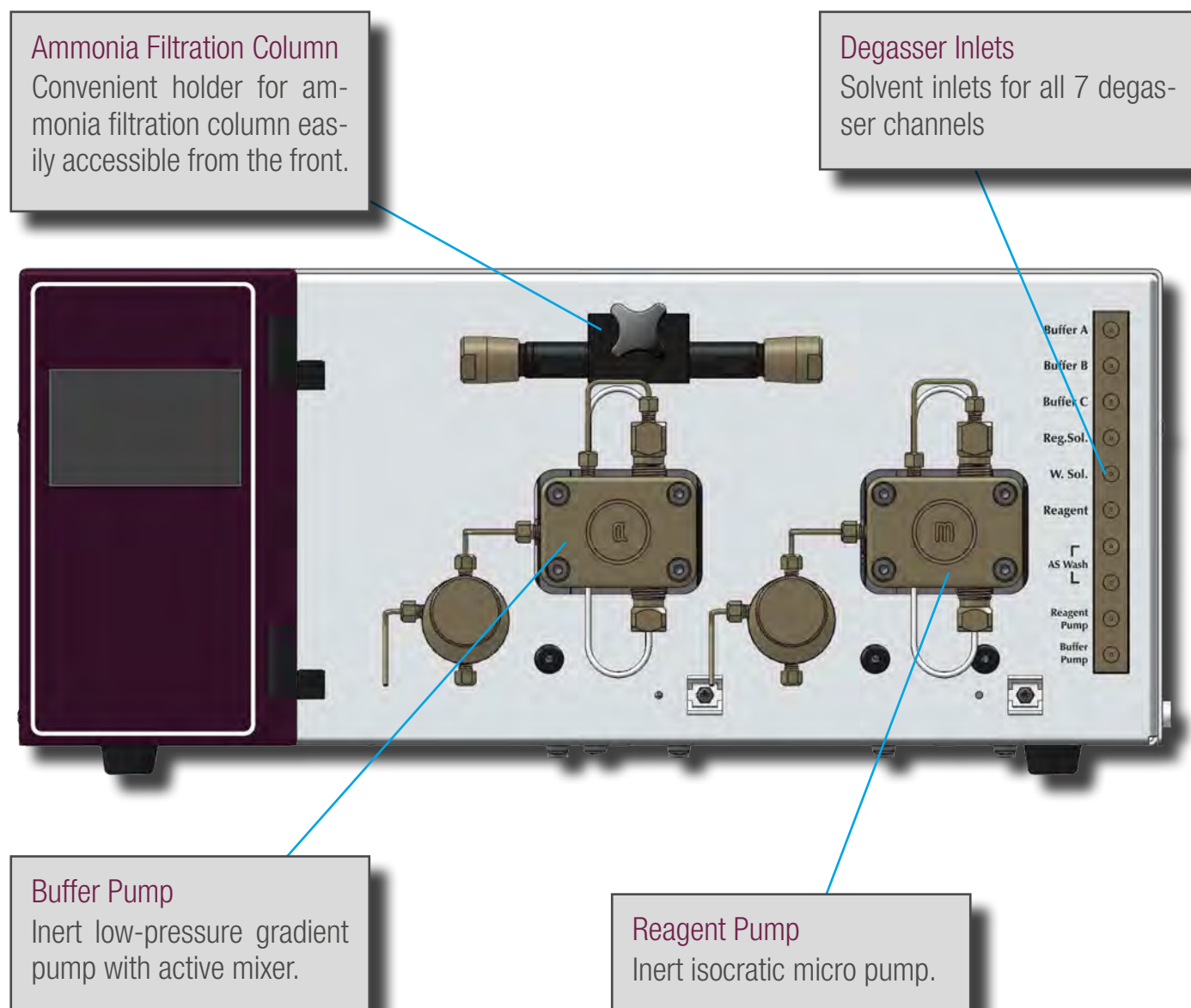

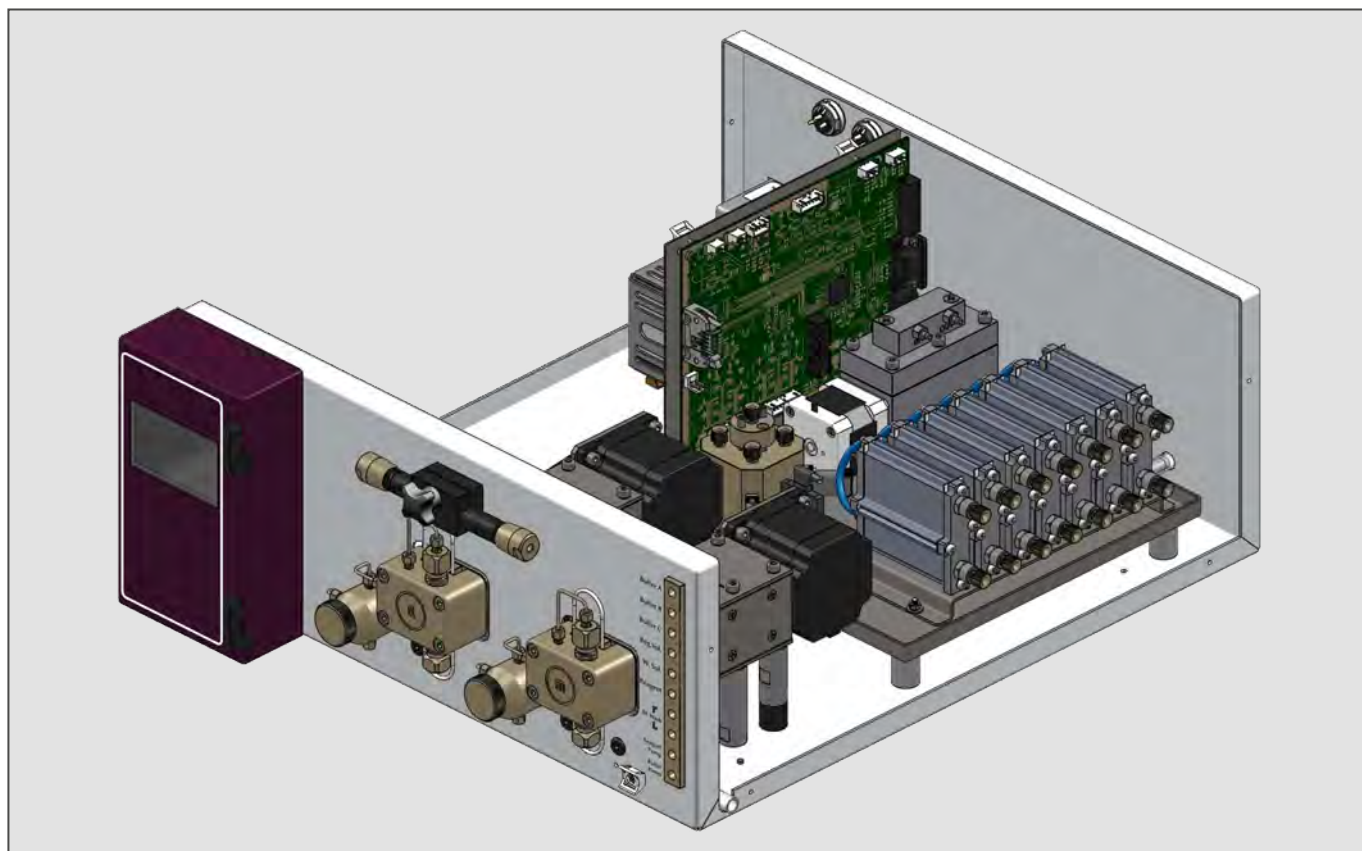

## TECHNICAL SPECIFICATIONS

### S 633-P Pump Module

<b>Wetted Materials:</b>	PEEK, PTFE, Teflon AF
<b>Dimensions:</b>	396 x 165 x 478 mm (WxHxD)
<b>Power Supply:</b>	100 - 250 ~V (47 - 63 Hz)
<b>Power Consumption:</b>	max. 300 W

### S 633-P Gradient Pump

<b>Flow Range:</b>	0.0001 - 10.000 ml/min
<b>Flow Accuracy:</b>	< 1.0% RSD at 0.45 ml/min
<b>Flow Precision:</b>	< 0.1% RSD at 0.45 ml/min
<b>Max. Pressure:</b>	350 bar (5076 psi)
<b>Gradient:</b>	low pressure gradient with active mixer
<b>Gradient Mixer Volume:</b>	100 - 950 µl; adjustable
<b>Gradient Accuracy:</b>	< 1.0% at 1.0 ml/min
<b>Gradient Precision:</b>	< 0.1% RSD at 1.0 ml/min
<b>Propulsion:</b>	stepper motor

### S 633-P Reagent Pump

<b>Flow Range:</b>	0.0001 - 2.000 ml/min
<b>Flow Accuracy:</b>	< 1.0% RSD at 0.25 ml/min
<b>Flow Precision:</b>	< 0.1% RSD at 0.25 ml/min
<b>Max. Pressure:</b>	350 bar (5076 psi)
<b>Propulsion:</b>	stepper motor
<b>Solvent Selection:</b>	solenoid valve (closed, washing, reagent)

### S 633-P Online Degasser

<b>No. Channels:</b>	7
<b>Degassing Efficiency:</b>	< 20% solved gases
<b>Internal Volume:</b>	< 400 µl / channel
<b>Propulsion:</b>	stepper motor
<b>Channel Usage:</b>	<ul style="list-style-type: none"> <li>• Buffer A</li> <li>• Buffer B</li> <li>• Buffer C</li> <li>• Reg.Solution</li> <li>• Washing Solution</li> <li>• Ninhydrine Reagent</li> <li>• Autosampler Wash</li> </ul>

# AUTOSAMPLER MODULE S 633-A

The **Autosampler Module S 633-A** features a mechanically durable X/Y/Z-Sampling-Mechanic designed for long life operation. The self-lubricating bearings keep the routine maintenance at a minimum and avoid troubles caused by dusty environments.

High precision stepper motors drive the X/Y axis for accurate positioning. Microstepping mode enables a high resolution for the syringe dosing and vial positioning.

## Dual-Needle Design

The Dual-Needle design of the autosampler avoids system blockages due to septum particles injected into the system. The ventilation needle pierces the septum before the injection needle moves into the sample vial (see figure on the right).

As the more fragile injection needle does not need to

pierce the vial septum, stronger vial caps or plastic vials can be used without problems.

## Sample Cooling

The sample racks can be cooled down to 5°C to handle temperature sensitive sample material.

## Optional Pre-Column Derivatization

The autosampler module can optionally be equipped with an automatic pre-column derivatization feature to run high sensitive samples with fluorescence detection.

### Front Door

The sample cabinet is closed with a door for easy access and good temperature stability.

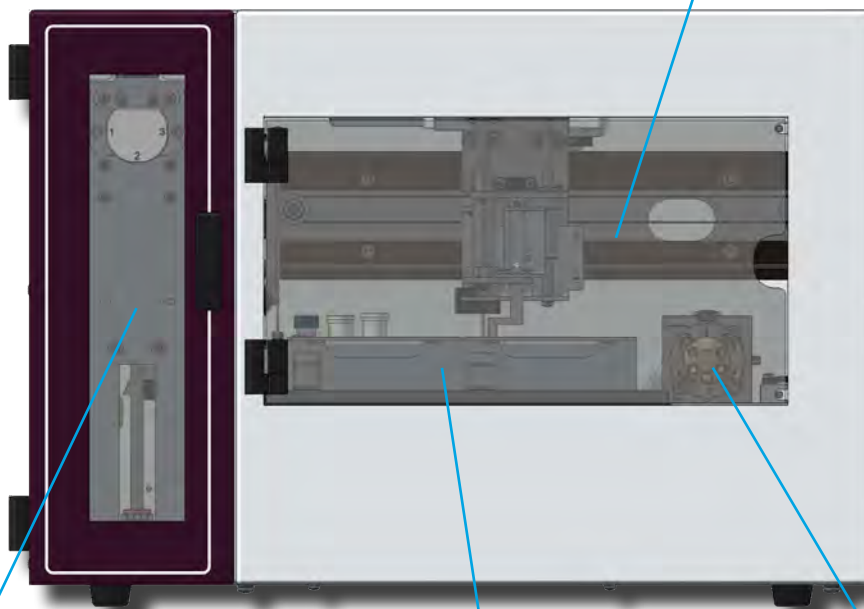

### Dosing Syringe

Easy access for troubleshooting and maintenance.

### 120 Vial Capacity

The standard sample racks have a capacity of 120 1.5ml vials.

### Injection Valve

The injection valve is easily accessible from the front.

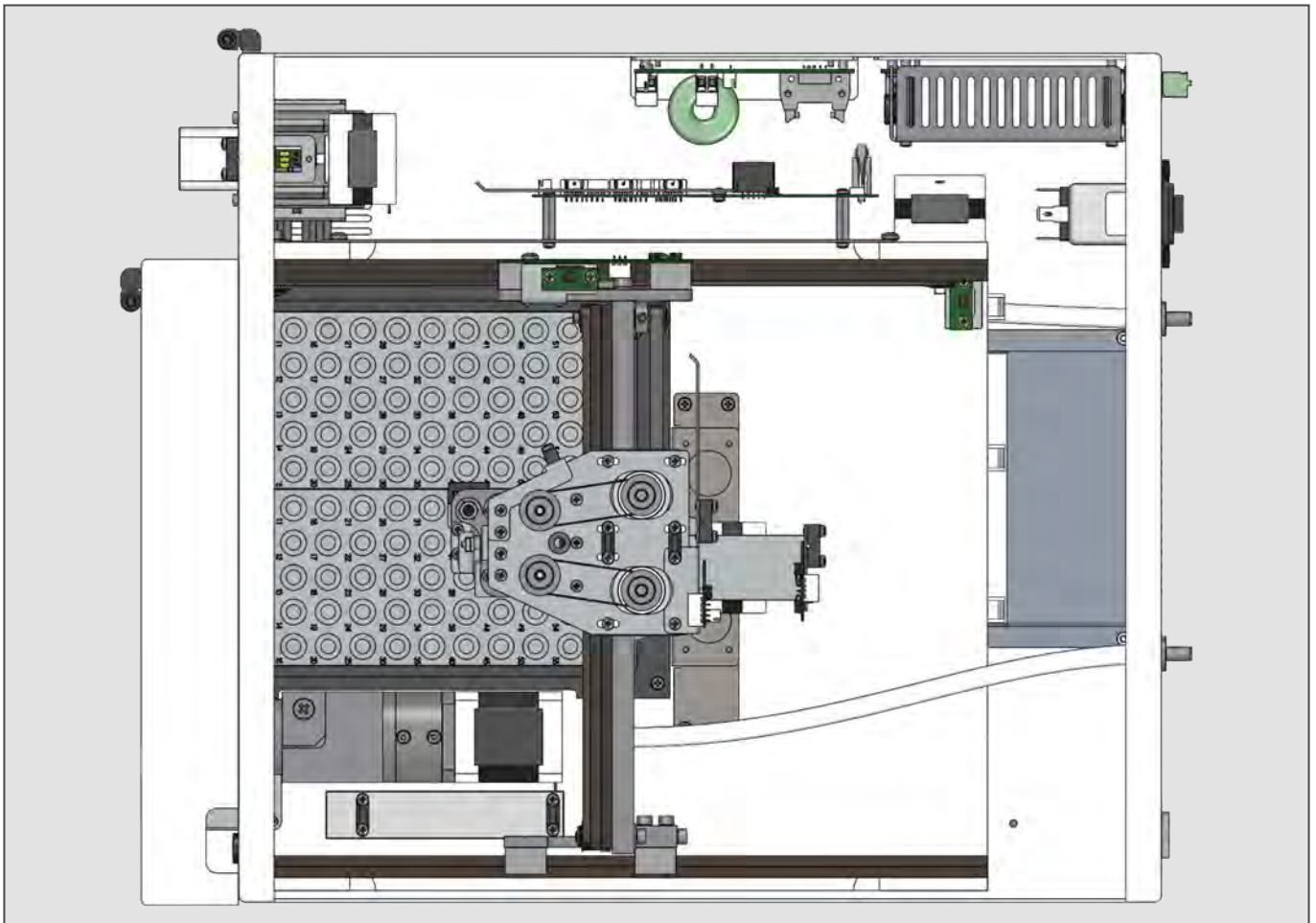

## TECHNICAL SPECIFICATIONS

### S 633-A Autosampler Module

<b>Wetted Materials:</b>	PEEK, PTFE, PVDF
<b>Sample Capacity:</b>	120 (1.5 ml), 192 (microtiter plate; optional)
<b>Injection Volume:</b>	0.1 - 999.9 $\mu$ l
<b>Injection Precision:</b>	< 0.5% RSD variable volume injection
<b>Carry Over:</b>	< 0.05 %
<b>Sample Cooling:</b>	+5°C to +60°C (at 20°C ambient temperature)
<b>Dimensions:</b>	396 x 165 x 478 mm (WxHxD)
<b>Power Supply:</b>	100 - 250 ~V (47 - 63 Hz)
<b>Power Consumption:</b>	max. 300 W

### Dual-Needle Injection

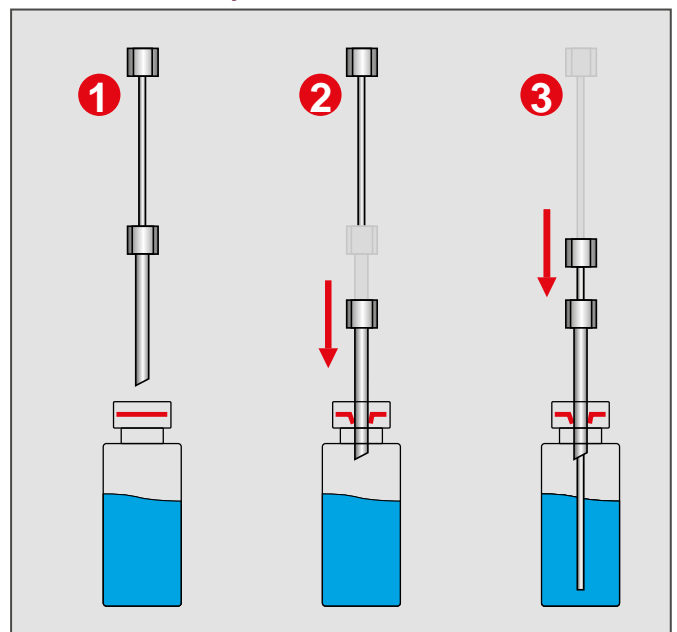

# REACTION MODULE S 633-R

The *Reaction Module S 633-S* is a post-column derivatization module. The module consisting of three major parts:

## 1.) Column Oven

The integrated column oven has a temperature range from +30°C to 99° C and is capable of temperature gradient programs.

## 2.) High Temperature Reactor

The high temperature reactor (30°C to 150 °C) guarantees a stable and fast ninhydrine reaction for consistent results.

## 3.) 2-Channel LED Detector

The integrated 2-Channel (440 & 570 nm) detector uses wavelength-specific LED with a narrow bandwidth. The lifetime and wavelength stability is much better than the conventionally used tungsten lamp.



# TECHNICAL SPECIFICATIONS

## S 633-R Reaction Module

<b>Wetted Materials:</b>	PEEK, PTFE, Quarz glas
<b>Dimensions:</b>	396 x 165 x 478 mm (WxHxD)
<b>Power Supply:</b>	100 - 250 ~V (47 - 63 Hz)
<b>Power Consumption:</b>	max. 300 W

## S 633-R Column Oven

<b>Temperature Range:</b>	30°C to 99 °C; gradient capable
<b>Temperature Accuracy:</b>	< 1.0°C at 60 °C
<b>Temperature Precision:</b>	< 0.2°C at 60 °C
<b>Temperature Control:</b>	peltiers
<b>Other Features:</b>	column saver

## S 633-R Reactor

<b>Temperature Range:</b>	30 °C to 150 °C
<b>Temperature Accuracy:</b>	< 1.0°C at 130 °C
<b>Temperature Precision:</b>	< 0.5°C at 130 °C
<b>Temperature Control:</b>	heating foil
<b>Reactor Type:</b>	PTFE capillary coil
<b>Other Features:</b>	temperature fuse

## S 633-R Detector

<b>No. Channels:</b>	2 (570 & 440 nm)
<b>Light Source:</b>	wavelength specific LED
<b>Pathlength:</b>	20 mm
<b>Flowcell Volume:</b>	< 80 µl
<b>Baseline Noise:</b>	< 200 µAu
<b>Baseline Drift:</b>	< 3x 10 <sup>-4</sup> AU/hr
<b>Other Features:</b>	channel signal addition



**Column Saver**

Integrated column saver feature to increase the column lifetime.

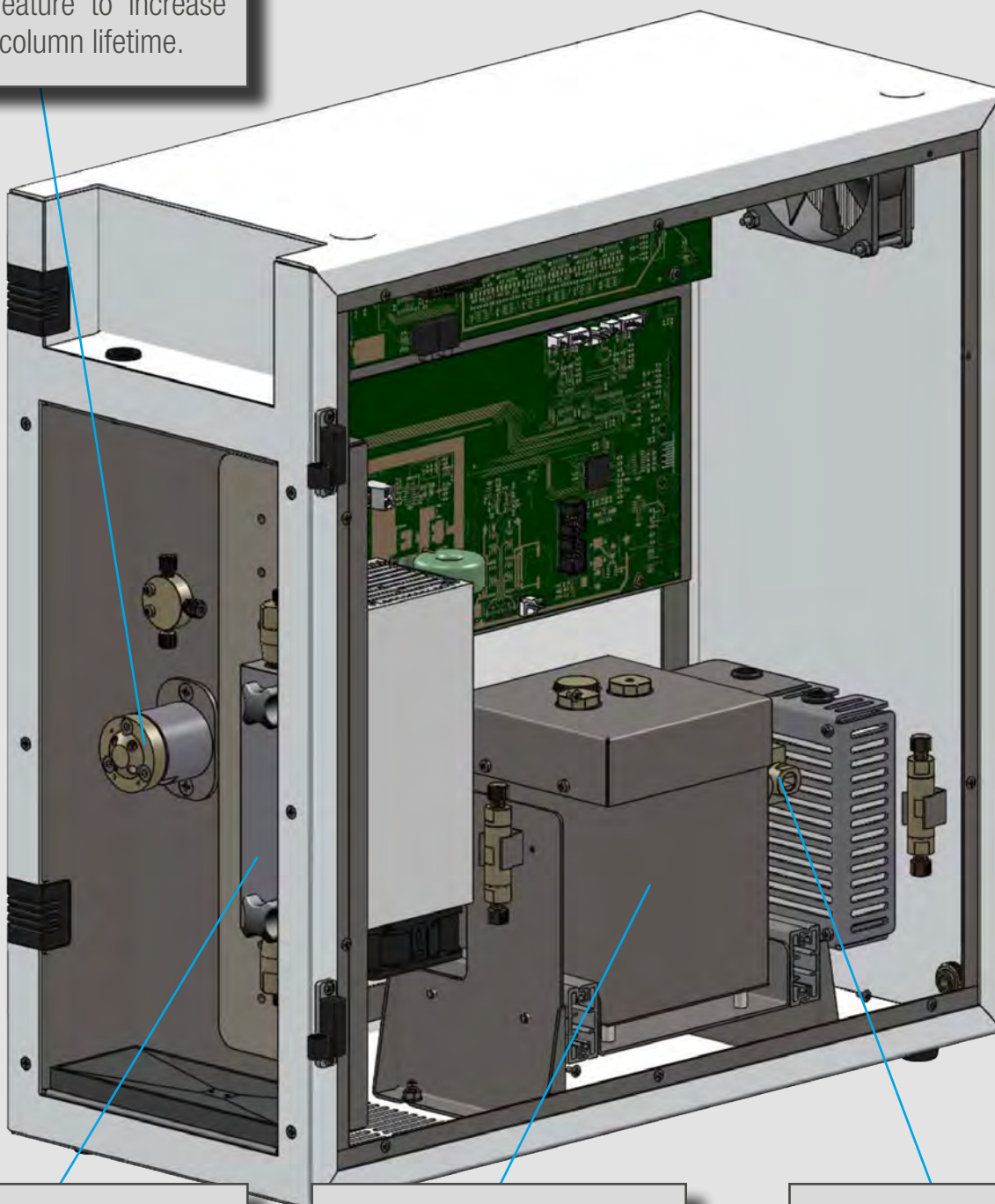

**Column Oven**

Integrated column oven with temperature gradient capability from 30 to 99 °C.

**High-Temperature Reactor**

PTFE coil reactor with a temperature range from 30°C to 150°C.

**Detector**

2-Channel LED  
Detector (440 &  
470nm)

# REAGENT ORGANIZER S 7135 / S 7136

The *Reagent Organizer S 7135* is an integral part of the amino acid analyzer.

The integrated cooling unit temperates the buffers and especially the ninhydrine reagent to ~ 15°C.

This increases the stability of the ninhydrine reagent considerably.

Alternatively, the non-cooled *Reagent Organizer S 7136* is available for system with high sample throughput where the ninhydrine lifetime is not critical.

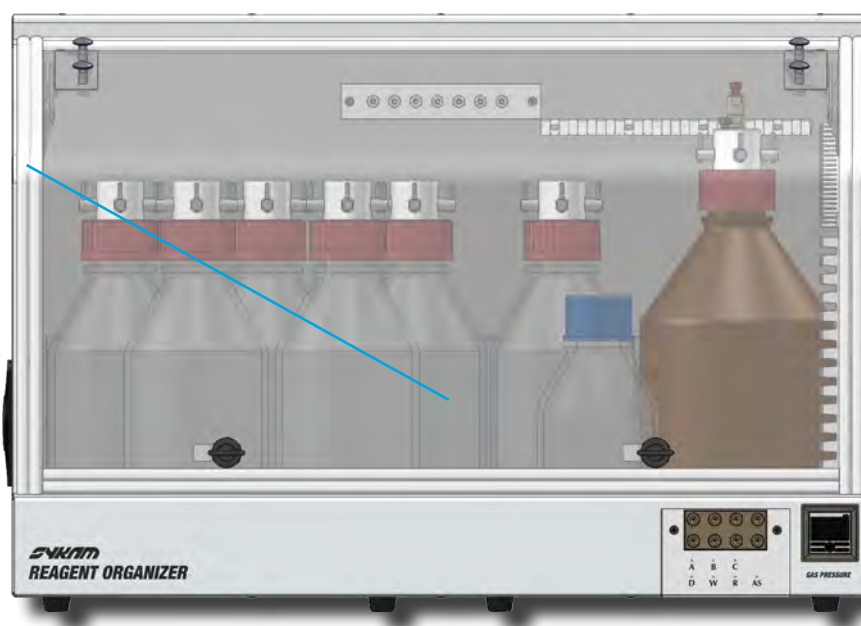

## EASY MAINTENANCE

The system offers easy access to all necessary parts for routine maintenance and service.

Almost everything can be accessed from the front, except flowcell and reactor which can be comfortably accessed from the instrument's side side.

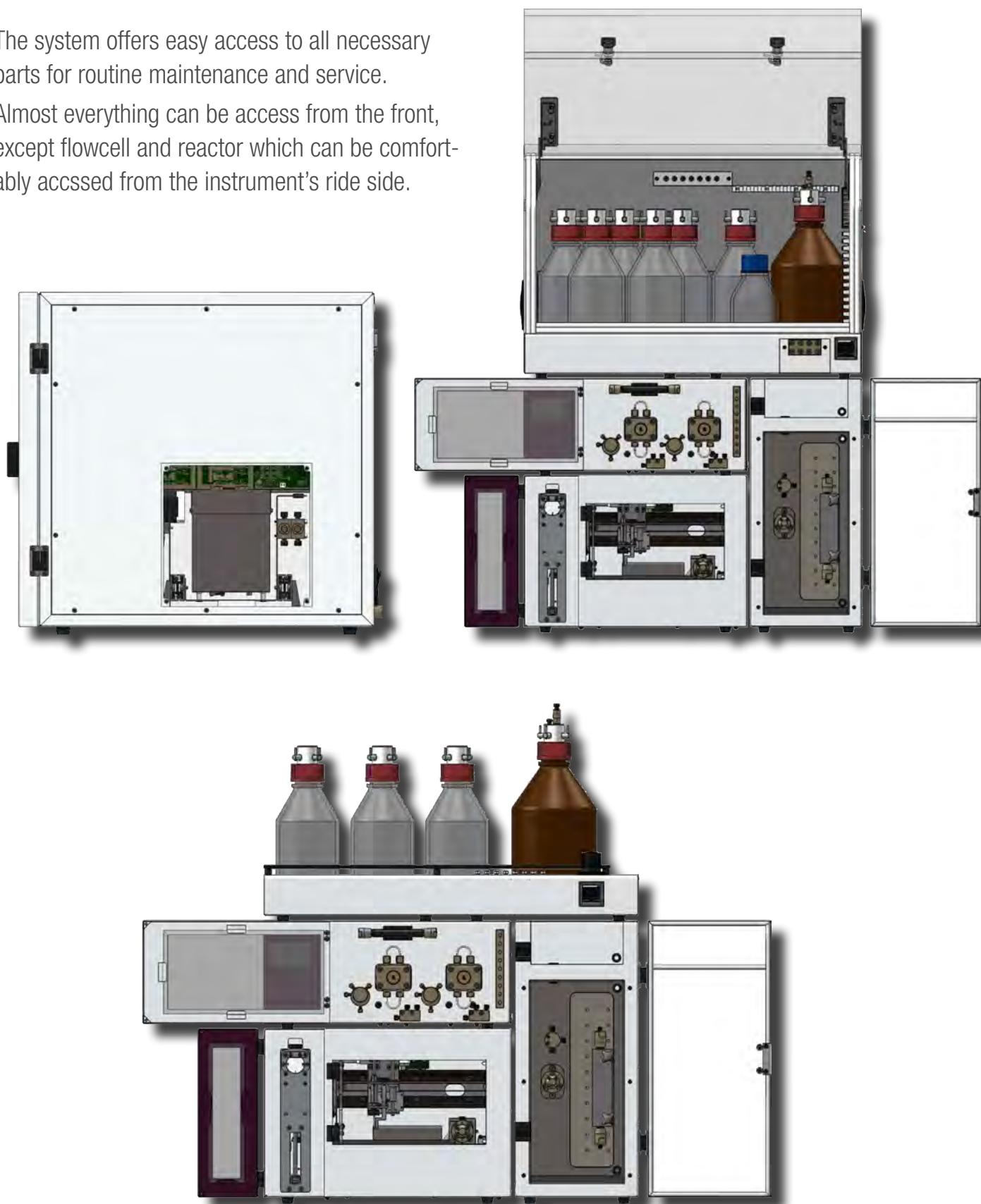

## **Sykam GmbH**

Systeme & Komponenten analytischer Meßtechnik

